

# MGS – Murco Gas Sensor

## Check / Calibration Procedure\*

Content	Page
1- Introduction	2
2- Bump Test	2
3- Calibration	3
4- Additional recommendations	3
5- Normalisation	3
6- Sample Test Certificate for System Log	4



### **\*Technician use only**

*These units must be checked /tested and /or calibrated by a suitably qualified technician who must test or calibrate the unit in accordance with the instructions as provided or set out in the relevant manual and the standards set down in their particular industry/country. Suitably qualified operators of the unit should be aware of the regulations and standards set down by their industry/country for the testing or calibration of this unit. These notes are only intended as a guide and insofar as permitted by law the manufacturer accepts no responsibility for the Calibration and Testing or operation of this unit.*

*Failure to test or calibrate the unit in accordance with the then applicable instructions and with industry guidelines may result in serious injury including death and the manufacturer is not liable for any loss injury or damage arising from improper testing or calibration or inappropriate use of the unit.*

*The testing or calibration of the unit must be carried out by a suitably qualified technician, in accordance with the testing or calibration manual and in compliance with locally applicable guidelines and regulations.*

10 ASH (1)

Murco Ltd.  
114a Georges Street Lower, Dun Laoghaire Co Dublin. Ireland,  
e-mail: [info@murco.ie](mailto:info@murco.ie) web: [www.murcogasdetection.com](http://www.murcogasdetection.com)



## 1- INTRODUCTION

The frequency and nature of testing or calibration may be determined by local regulation or standards.

EN378 and the FGAS Regulation require an annual check in accordance with the manufacturer's recommendation.

**Murco recommends annual checks by bump test, and gas calibration on site at two yearly intervals in the case of semiconductor SC sensors and infrared IR sensors with sensor replacement every five years or as required. In the case of electrochemical EC sensors we recommend annual bump test and sensor replacement at two yearly intervals and gas calibration. This should eliminate end of life concerns, and constantly renew the detection system. If the MGS is exposed to a large leak it should be tested to ensure correct functionality by electrically resetting the zero setting and carrying out a bump test, see procedures below.**

There are two concepts that need to be differentiated: bump test and calibration

**Bump Test:** This consists of exposing the sensor to a gas and observing its response to the gas. The objective is to establish if the sensor is reacting to the gas and all the sensor outputs are working correctly. There are two types of bump test.

**Quantified:** where a known concentration of gas is used, or  
**Non-Quantified:** where a gas of unknown concentration is used.

**Calibration:** This consists of exposing the sensor to a calibration gas, setting the "zero" or "Standby voltage", the span / range, and checking/adjusting all the outputs, to ensure that they are activated at the specified gas concentration.

Procedures for bump test and calibration vary depending on the sensor technology used and the gas in question. The MGS is available in three sensor versions: Semiconductor (**SC**), Electrochemical (**EC**) and infrared (**IR**).

## 2- BUMP TEST (every year)

Ideally bump tests are conducted on site in a clean air atmosphere.

Prior to carrying out a bump test, check and adjust the zero setting as described in the Calibration section page 3 - Sensor PCB 1.1 and 2.2.

**2.1 Semiconductor and IR sensors for hydrocarbons:** We offer cylinders of gas at known concentrations for quantified tests. This consists of exposing the sensor to the gas and checking that alarm lights and relays are activated. If this is not available, for a non-quantified test you can use a gas cigarette lighter. By cracking open the valve without igniting the gas, you release the gas onto the sensor and force it into alarm. Check that alarm light, sounder and relay are activated.

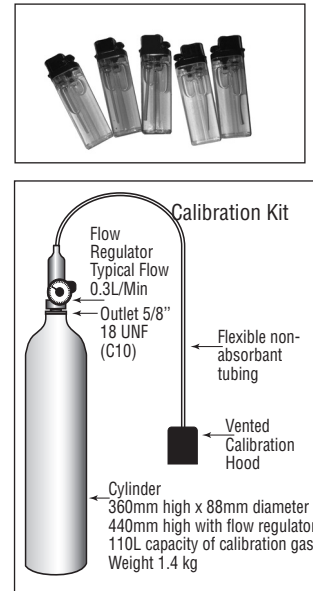

Before you carry out the test or calibration:

- 1- Advise occupants, plant operators, and supervisors.
- 2- Check if the MGS is connected to external systems such as sprinkler systems, plant shut down, external sirens and beacons, ventilation, etc. and disconnect as instructed by the customer.
- 3- Deactivate alarm delays if selected at JP5, JP6 as per instructions in Diagram 1.
- 4- For Bump Test or Calibration the MGS should be powered up overnight. If the unit has been installed and running for about 24 hrs, and you need to power it off for a short time to set the delay at 0 min, then the normalisation period is about 5 min (this is indicated by the green LED flashing) and then you can begin the testing or calibration. If sensors have been in long-term storage or the detectors have been turned off for a long time, normalisation would be much slower. However within 1-2 hours the sensor should have dropped below the alarm setting and be operational. You can monitor normalisation progress exactly by monitoring the sensor output, on CON 2 between pins OV & VS. See Section 5.

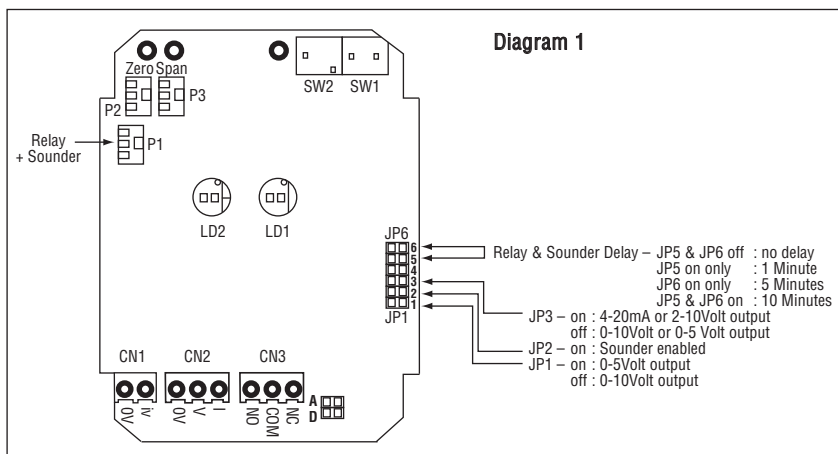

**2.2 Electrochemical sensors:** We offer Ampoules of ammonia (NH<sub>3</sub>) at 100ppm and 1.000 ppm. Cylinders of calibration gas are also available. These are a quantified test. For details of other Ampoules, please contact us.

**2.3 Infrared sensor for CO<sub>2</sub>:** We offer Ampoules of CO<sub>2</sub> at 5000 ppm. Cylinders of calibration gas are also available. These are a quantified test. If these are not available, then you can breathe on the sensor. Human breath has enough CO<sub>2</sub> to trigger the alarm. This is a non-quantified test.

### 2.4 Bump test using gas ampoules:

- 1- Make sure that both the ampoules and the calibration beaker are clean and dry.
- 2- Unscrew the beaker hold screw and place the ampoule so that it sits in the base of the beaker. As per illustration.

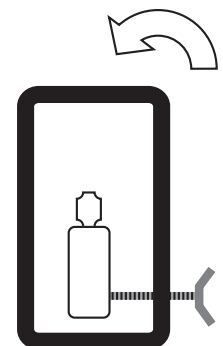

- 3- Tighten on the screw ampoule without breaking it.
- 4- Remove the enclosure lid of the gas detector (not in Ex area).
- 5- Connect voltmeter to monitor sensor response, monitor 0-10v (Jumper JP1 and JP3 off) response on CON 2 between pins OV & V.
- 6- Place the beaker over the sensor head using the multi sensor adaptor to fit the sensor, or, if an Exd, IP66 or Remote sensor head version, screw the beaker on the remote sensor head M42 thread, or M35 thread adaptor. It should be as tight fitting as possible to allow maximum exposure to the gas.

- 7- Tighten on the ampoule until it shatters allowing the contents to diffuse in the beaker. It should be left in place for approximately 5 min.
- 8- Voltage output will increase. This confirms that the sensor is responding. In the case of an ampoule quantified test a response equivalent to at least 50% of the test gas will confirm that the system is in order.
- 9- Carefully remove any ampoule remains from the gas detector and beaker.

## 2.5 Bump Test Using Gas Cylinders.

Remove the enclosure lid of the gas detector (not in an Ex area). Connect voltmeter to monitor sensor response, monitor 0-10V (Jumper JP1 and JP3 off) response on CON 2 between pins 0V & V. Expose the sensor to gas from the cylinder. You can place the entire MGS into a plastic bag or use a plastic hose/hood to direct gas to the sensor head. A response of above 80% is acceptable.

## 3- CALIBRATION

This is the adjustment of the gas detector's accuracy or recalibrating after sensor element exchange using calibration gas.

Murco offers a calibration kit that consists of a Calibration gas cylinder, a flow regulation valve with flexible non-absorbant tubing and vented calibration hood.

Tools required:

- 1- Gas can with the appropriate gas and concentration
- 2- A voltmeter- crocodile clips recommended
- 3- Estimate 30 min per sensor

The MGS has three sensor PCB versions: SC, EC, IR.

Calibration and alarm relay set point is done on a 0-5V scale.

### Adjusting the alarm relay

This process is the same for all versions. See diagram 2 and 3 for location of pot P1 and test points 0V and REF1.

The first step to setting the alarm relay at the desired levels:

- 1- Pot P1 is used to adjust the set point at which the relay activates. Monitor the output between test points 0V (negative) and REF1 (positive). See example below.

*Example:* For a range of 0-1000ppm, relay @ 100ppm  
 $\text{Relay} = 100 \text{ ppm} \times \frac{5}{1000}$  so that Alarm relay = 0.5 Volts  
 while the 0-5V output sensor signal corresponds to 0-1000 ppm range.

**Sensor PCB** – adjusting the detection range

### 1- Semiconductor Sensor (SC) (see Diagram 2)

There are two adjustments required: the zero and the span. They are monitored at 0V and VS on a 0-5V scale. If the target range is 0-1000ppm, and the gas used is 1000 ppm then  $5V=1000\text{ppm}$ .

Diagram 2

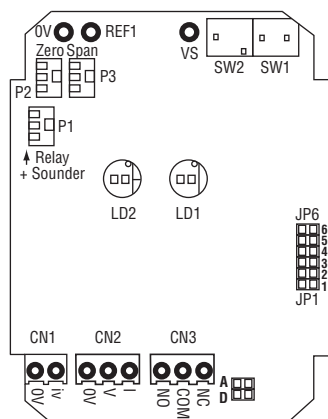

- 1.1- Pot P2 is used to adjust the zero of the range (span). Monitor the output between 0V (negative) and VS (positive) and adjust the Pot to 0 V or slightly positive (0.01 V is acceptable).
- 2.2- Pot P3 is used to calibrate the range (span) of the sensor. Monitor the output between 0V (negative) and VS (positive). Expose the sensor to calibration gas and allow to stabilise and adjust pot P3 to 5V.

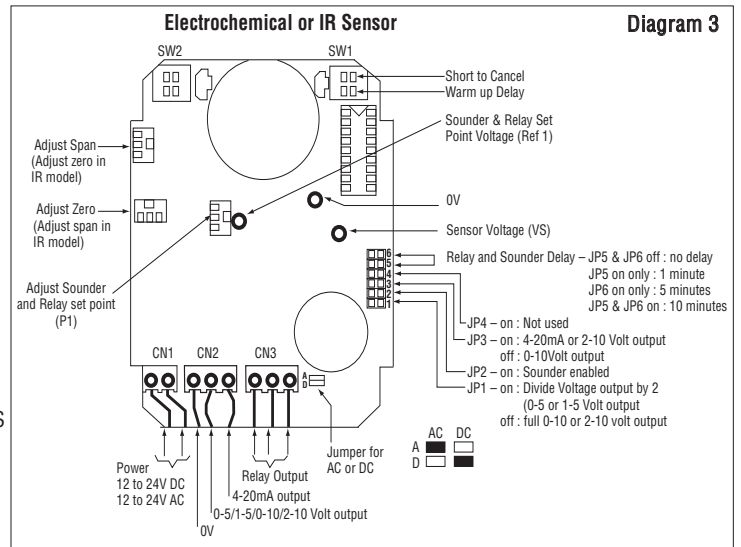

### 2- Electrochemical Sensor (EC) (see Diagram 3)

There are two adjustments required: the zero and the span. They are monitored at 0V and VS on a 0-5V scale. If the target range is 0-1000ppm, and the gas used is 1000 ppm then  $5V=1000\text{ppm}$ .

- 2.1- Pot VR201 is used to adjust the zero of the range (span). Monitor the output between 0V (negative) and VS (positive) and adjust the Pot to 0V or slightly positive (0.01 V is acceptable).
- 2.2- Pot VR202 is used to calibrate the range (span) of the sensor. Monitor the output between 0V (negative) and VS (positive). Expose the sensor to calibration gas and allow to stabilise and adjust pot VR202 to 5V.

### 3- Infrared (IR) (see Diagram 3)

- 3.1- Pot VR203 is used to adjust the zero of the range (span). Monitor the output between 0V (negative) and VS (positive) and expose the sensor to Nitrogen or zero air, and once stable, adjust the Pot to 0 V or slightly positive (0.01 V is acceptable).
- 3.2- Pot VR202 is used to calibrate the range (span) of the sensor. Monitor the output between 0V (negative) and VS (positive). Expose the sensor to calibration gas and allow to stabilise and adjust pot VR202 to 5V.

**NOTE:** Sensors outputs are linear, thus as long as you have a gas canister of known concentration you can calibrate to any desired range.

*Example:* For a range of 0-1000ppm, and a canister of the target gas at 800ppm  
 The 0-5V signal corresponds to 0-1000, thus if using the above canister:  
 $\text{Voltage} = 800 \text{ ppm} \times \frac{5}{1000} = 4V$  and so the output voltage signal should be adjusted to 4V.

## 4- ADDITIONAL RECOMMENDATIONS

**FALSE ALARMS:** If false alarms are being triggered by background gases, paint fumes, etc, extreme humidity or temperature conditions, you will find that the zero has moved to a + value, you can adjust the zero setting back to zero to compensate. You may also increase the response time delay to help eliminate false alarms.

## 5. Normalisation Period

Below we show typical time to normalize for various sensor types. The units are powered up and the output voltage monitored on the 0-10V-output. The approximate time to drop to near 0V is shown.

Sensor Type	Stabilised ~0V
Electro-Chemical	20-30 Seconds
Semi-Conductor	1-3 Minute
Infrared	2 Minute

The electro-chemical sensor on power up outputs a signal voltage normally below the set alarm level. Semiconductors output over the + max scale i.e. > 5V. Both move towards zero as they stabilise.

If sensors have been in long-term storage or the detectors have been turned off for a long period, normalisation would be much slower. However within 1-2 hours sensors should have dropped below the alarm level and be operational. You can monitor progress exactly by monitoring the 0-10V output, when the output settles around zero the sensor is normalised. In exceptional circumstances the process can take up to 24hours or more to get to 0V, again monitor the 0-10V output and you can see what is happening.

# MGS Test Certificate (Example)



(Download original from our web site [www.murcogasdetection.com](http://www.murcogasdetection.com). Use in Conjunction with the Murco Check Calibration Procedure)

**Product Description:** MGS

**Serial Number:** 12345

**Date of First Calibration:** (see Rating Label) 25/10/05

**Date of Last Calibration:** 25/10/05

**Type/Range of Test Gas:** Cylinder 1000ppm R404a, batch no xxxx

.....

## 1. Carry out Bump Test (Set delay to zero)

Power (Green LED) _____	<input checked="" type="checkbox"/>
Visual Alarm (Red LED) _____	<input type="checkbox"/>
Sounder Operating _____	<input type="checkbox"/>
Relay Operating _____	<input type="checkbox"/>
Remote Systems if connected to relay _____	<input type="checkbox"/>
<b>Check Analogue Output in Use, e.g.</b>	
0 – 10V _____	<input type="checkbox"/>
<b>System Passed</b> _____	<input type="checkbox"/>

If system failed, carry out a gas calibration. See below.

## 2. On site Gas Calibration (2 Yearly)

**System Passed** \_\_\_\_\_

If the MGS did not respond correctly and could not be recalibrated due to age, exposure to gas etc, then either the MGS or the sensor element should be replaced (and recalibrated) and the test process repeated.

**System Passed** \_\_\_\_\_

***We hereby certify that the above specified test procedure has been performed and the MGS is performing as specified.***

Test Performed by \_\_\_\_\_  
Signature Date